



an ISO 9001 : 2000 Certified Company

# Gas Pressure Regulators



# Gas Pressure Regulators

Type F-166 Regulators are self actuated for precise control of gas pressure for maximum combustion efficiency in commercial gas installation. The Regulators maintain the outlet pressure steadily irrespective of varying inlet pressure in the pipeline. These high capacity regulators are used as final control elements for burner application, installed just ahead of burner manifold in industrial furnaces.

## Self Acting Pressure Regulator F-166/HP

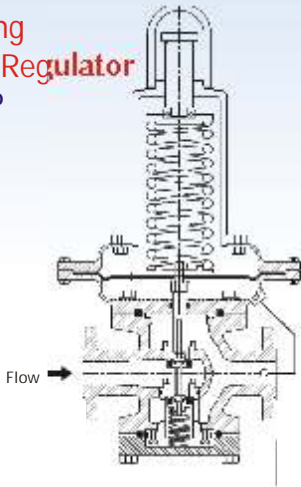

Series F-217 Regulators are Pilot operated for control of gas & air pressure. In single stage, pressure reduction can be achieved very precisely up to 1/10th of the inlet pressure. Pilot operated Regulator gives very precise downstream pressure and very low fluctuation.

## Pilot Operated Pressure Reducing Valve for Gas & Air F-217

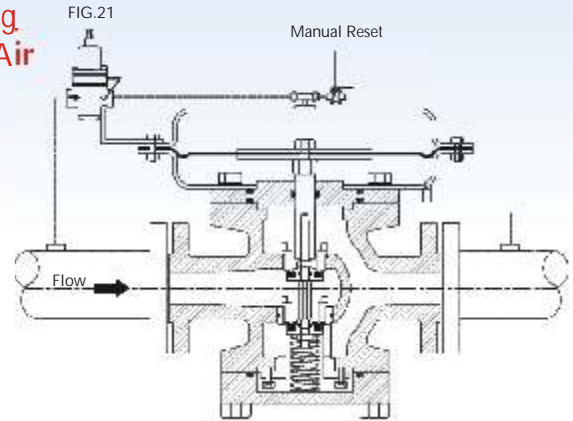

### Valve Dimensions are in mm

Valve Size (NB)	25	40	50	65	80	100	150	200
F/F Distance-150# (mm)	184	222	254	276	298	352	451	543
Value CV	9	18	35	50	65	105	250	450

## GAS SKIDS

Complete natural gas pressure regulating & metering skids are being supplied with gas filters, Isolation Valve, Meters, Safety Shut-off Valve & Regulating Valve. Ideal for individual industrial units and as a stand alone unit.



Darling Muesco (India) Pvt. Ltd.

Joint Venture with Anchor/Darling Valve Co.-USA

Plot No. 97 A, Phase-1, G.I.D.C. Vatva, Ahmedabad - 382 445. INDIA.

Phone: +91 79 2583-2578, 2589-3791 & 92, Fax: +91 79 2583 4392

E-mail: sales@darlingmuesco.com, Web.: www.darlingmuesco.com